

The Role of Penning Ionization of the Minor Species in a Neon Hollow Cathode Discharge

Kermit C. Smyth,*^{1a} B. L. Bentz,^{1b} C. G. Bruhn,^{1b,c} and W. W. Harrison*^{1b}

Contribution from the Center for Fire Research, National Bureau of Standards, Washington, D.C. 20234, and the Department of Chemistry, University of Virginia, Charlottesville, Virginia 22901. Received September 11, 1978

Abstract: Using a tunable dye laser, a neon hollow cathode discharge was irradiated at wavelengths corresponding to $1s_n \rightarrow 2p_n$ neon transitions, and thereby the neon metastable atom population was perturbed. At these wavelengths, changes were detected in both the voltage across the discharge and in the ion signals for the various neon species, as well as for minor (including sputtered) species in the discharge. Attention is focused on the several possible ionization mechanisms for the minor species. Our results suggest that Penning ionization by metastable neon atoms plays the most important role at low discharge currents, but only a minor role at high currents.

I. Introduction

The glow discharge, including the hollow cathode mode, has been used as an atomization,² excitation,³⁻⁵ and ionization⁶⁻⁸ source for trace element analysis. The utility of this discharge stems from ion bombardment of the cathode (sample), which sputters off a significant population of neutral atoms, a fraction of which is then subsequently excited and ionized in the discharge plasma.

Ionization mechanisms have not been clearly defined in the glow discharge. Electron impact ionization certainly plays a significant,⁹ perhaps even dominant,¹⁰ role, depending upon experimental conditions. However, Penning ionization¹¹ has also been suggested¹² as a major contributor, particularly at the pressures used in the hollow cathode discharge. A general reaction for this ionization process is written:



where M is an atomic species (a sputtered metal atom, for example), and Ne* represents a metastable neon excited state.

The ability to alter the population of the neon metastable species would thus be of interest from an analytical standpoint. If Penning ionization occurs to a significant degree, the enhancement of the metastable population would increase the sensitivity for the analyte M when sampling M^+ by mass spectrometry. Further, an indication of the involvement of the metastable species in the ionization process might be obtained by varying the Ne* concentration.

The recent reports concerning the optogalvanic effect¹³⁻¹⁵ describe the use of a continuously tunable laser to excite selected neon energy levels which influence the metastable atom population. The observed changes in Ne⁺ concentration in a neon discharge indicate that photon irradiation alters the overall ionization rate.¹⁵ In this study, we report on laser-induced effects in a neon hollow cathode discharge, where our interest primarily centers on the ionization mode of the minor discharge species, including sputtered cathode atoms.

II. Experimental Section

Figure 1 illustrates the apparatus. The mass spectrometer for analyzing solids was a hollow cathode ion source coupled to a quadrupole mass filter; this instrument has been described previously.^{16,17} The present study required modification of the ion source to facilitate laser irradiation of the discharge. An alternative anode configuration was used, positioned approximately 5 mm off axis and parallel with the hollow cathode. This allowed unobstructed laser illumination of the hollow cathode cavity through a quartz window at the entrance of the ion source. Hollow cathodes of 2.54-cm length, 2.49-cm depth, 0.47-cm i.d., 0.61-cm o.d., and with a 0.5-mm nozzle orifice diameter drilled in the cathode end wall were machined from copper and

graphite stock material. The anode-cathode distance was 1 cm, and the discharge gas was neon.

The laser beam from a CW tunable dye laser (Coherent Model 590 pumped by a 4-W Spectra-Physics Model 164 argon-ion laser¹⁸) was directed axially along the bore of the hollow cathode. Neon transitions were investigated in the 585–625-nm wavelength range, with typical powers of 80–330 mW (using Rhodamine 6G and Rhodamine B dyes) in a beam diameter of 2–3 mm and with a bandwidth of ~0.05 nm. The laser wavelength was optimized using the optogalvanic signal measured in a commercial hollow cathode lamp with neon fill gas.¹⁴ For this optimization a mechanical chopper provided laser beam modulation, and the resultant discharge voltage changes were displayed on an ac coupled oscilloscope.

Laser-induced voltage changes varied from 0.05 to 7 V, with the largest signals corresponding to a 2% change in the anode-cathode voltage. The hollow cathode ion source allowed discharge currents and pressures to be widely varied, with discharge conditions of 5–10 mA and 2–3 Torr (1 Torr = 133 Pa) neon pressure yielding significant voltage and ion current changes upon laser irradiation. The response of the discharge ion species upon irradiation was measured by tuning the quadrupole mass filter to transmit only the ion of interest and monitoring the ion signal changes on a strip chart recorder as the laser beam was manually interrupted.

III. Results

The neon hollow cathode discharge was irradiated with light in the 585–625-nm wavelength region, and a number of neon absorption transitions were detected by monitoring voltage changes across the discharge. All of these transitions originate in high-lying electronic states. The lowest excited electronic configuration of neon [$2p^53s$] yields four states, designated $1s_5$, $1s_4$, $1s_3$, and $1s_2$ in Paschen notation. Two of these states are long-lived metastables ($1s_5$ and $1s_3$), while the other two have very short radiative lifetimes to the ground state.¹⁹ Transitions were observed from each of these $1s$ states to the $2p$ levels (ten states), but higher lying transitions originating in the $2p$ states were difficult to detect.

Both positive and negative voltage changes were observed, with the former being much larger under our experimental conditions. In general, a large voltage change upon laser irradiation correlated with large changes in ion signals for a number of species in the discharge (in agreement with earlier work¹⁵). Table I shows such effects for irradiation of the 594.48-nm ($1s_5-2p_4$) transition in neon, where a positive voltage change was observed, corresponding to a decreased conductivity in the discharge. The changes in ion signals are negative and substantial (20–25% decreases at low discharge currents). Similar results, but with smaller relative voltage and ion signal changes, were obtained for the 588.19- ($1s_5-2p_2$), 597.55- ($1s_5-2p_5$) and 609.62-nm ($1s_4-2p_4$) transitions. For each of these lines a positive voltage change and corresponding decreases in the ion signals were detected. Unfortunately, it

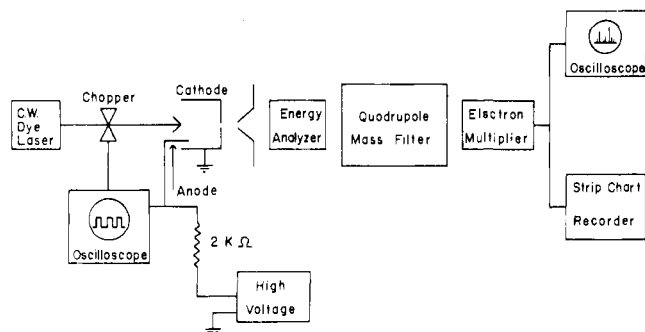

Figure 1. Schematic diagram of the apparatus.

did not prove possible to carry out the converse experiment, namely, to observe ion signal changes upon irradiation of neon transitions which gave a negative voltage change. Only small negative voltage signals (always less than 1 V) were detected for four such neon transitions; no ion signal changes were observed. Our signal to noise ratio for the ion signals prevented measuring changes smaller than $\sim 1\%$.

When the laser wavelength did not correspond to a neon transition, ion signal changes of ~ 1 – 8% were still detected for all species in the discharge. In general, this off-resonance signal produced enhanced ion signals, possibly due to photoionization of high-lying electronic states which are populated by electron collisions in the discharge. All of the results have been corrected for this effect.

IV. Discussion

Eleven $1s \rightarrow 2p$ transitions in neon were detected during this work by measuring voltage changes across the discharge. Those transitions which originate in the metastable $1s_5$ and $1s_3$ states always exhibited a positive voltage change, while voltage signals of either sign were observed for transitions originating in the $1s_4$ and $1s_2$ states, depending upon current and pressure conditions. These results are consistent with previous experiments on neon discharges,^{14,15} which have been interpreted in terms of photon-induced changes in the rates of one or more ionization processes. Certainly one of the most important of these processes is ionization due to metastable–metastable collisions:



Photon excitation of a $1s \rightarrow 2p$ transition directly affects the metastable atom population, and thus ionization in the discharge. This can be understood by considering the radiative decay of the $2p$ levels. $2p \rightarrow 1s$ transitions will in general populate both the metastable $1s_5$ and $1s_3$ states and the non-metastable $1s_4$ and $1s_2$ states (radiative decay directly to the ground state is parity forbidden). Thus, photon excitation out of the metastable neon states will decrease the metastable atom population, and thereby decrease ionization of neon atoms in the discharge, while simultaneously enhancing the $1s_4$ and $1s_2$ levels which radiate efficiently to the ground state. Conversely, excitation from the nonmetastable $1s$ levels will produce an increased metastable atom population and thus increased neon ionization. The cross sections and branching ratios for the radiative decay of the $2p$ levels have been measured.²⁰

Thus, simple radiative $2p \rightarrow 1s$ decay predicts the positive voltage changes observed upon photon excitation of the $1s_5 \rightarrow 2p$ transitions. In addition, it is not surprising to find that the 594.48-nm ($1s_5 \rightarrow 2p_4$) line exhibited large voltage and ion signal changes in this work, since the $2p_4$ level radiates to the nonmetastable $1s_4$ and $1s_2$ states with a cross section four times larger than to the metastable levels.²⁰ On the basis of radiative arguments alone, one predicts the largest changes in metastable

Table I. Photon-Induced Ion Intensity Changes in a Neon Discharge^a

wavelength, nm	voltage change, V	ion current changes for selected species, %	
594.48	+7.0	$^{20}\text{Ne}^{2+}$	–22
		$^{12}\text{C}^+$	–20
		$^{14}\text{N}^+$	–24
		$^{20}\text{Ne}^+$	–24
		$^{20}\text{Ne}_2^+$	–21

^a Graphite cathode, 2.0 Torr, 5 mA, 330 V, 250 mW laser power.

atom population to occur for excitation of the $1s_5 \rightarrow 2p_4$ transition.

For a neon discharge, photoionization of excited neon states and electron impact ionization will also contribute to ionization:

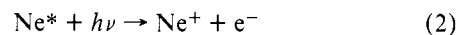

Energetic photons arise from radiative decay of the $1s_4$ and $1s_2$ states to the ground state [at 74.37 (16.67 eV) and 73.59 nm (16.85 eV), respectively]. Photon excitation of a $1s_5 \rightarrow 2p$ transition will decrease the metastable atom concentration (Ne^*) and increase the number of energetic photons. Thus, the rates of (1), (2), and (3) will decrease upon photon irradiation [the effect will be small for process (2)], and the Ne^+ signal would be expected to decrease. This result is observed.¹⁵

Of particular interest in this work is the behavior of the ion signals due to the minor (including sputtered) species, such as C, N, and Cu, upon laser irradiation at wavelengths corresponding to the neutral neon transitions. Our results indicate that Penning ionization is the most important process for ionization of these minor species at low discharge currents. There are four processes by which a minor species M may be ionized in a neon discharge. The first three are analogous to the three processes described above for a pure neon discharge:

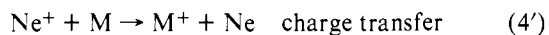
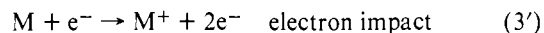
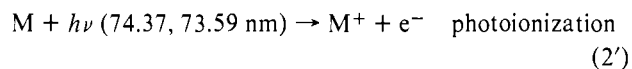
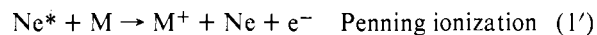

Photon excitation of a $1s_5 \rightarrow 2p$ transition of neon will now decrease the rates of (1') and (4'), increase the rate of (2'), and leave (3') unchanged to first order. Actually, the decrease in the metastable neon atom concentration will also lead to a decrease in the electron concentration [processes (1)–(3) above], and thus the rate of (3') will decrease somewhat. However, this effect is small, since the discharge voltage change upon laser irradiation is less than 2%.

Experimentally, the C^+ , N^+ , and Cu^+ ion signals always decreased upon irradiation at wavelengths corresponding to several $1s_5 \rightarrow 2p$ neon transitions. Thus, one immediate conclusion is that the ionization of the minor species in a neon discharge is not dominated by photoionization. This result is consistent with the small cross sections ($\sim 1 \times 10^{-17} \text{ cm}^2$) observed and calculated for photoionization of C,^{21–23} N,^{24,25} and Cu.²⁶

Our experiments do not distinguish between Penning ionization (1') and charge transfer (4') for ionizing the minor species. However, the cross sections for charge transfer at thermal energies are expected to be small when the ionization potentials of the two atomic species are widely different,^{27–29}

Table II. Effect of Discharge Current on Photon-Induced Ionization Changes in a Neon Discharge^a

wavelength, nm	discharge current, mA	voltage change, V	⁶³ Cu ⁺ change, %
594.48	4		-6.6
	10		-3.6
	20	+1.5	-3.3
	30	+1.0	-(~0.5)
	40	+0.7	no change

^a Cu cathode, 2.0 Torr. 295–330 mW laser power.

as is the case here (neon IP = 21.56 eV, carbon IP = 11.26 eV, nitrogen IP = 14.53 eV, and copper IP = 7.73 eV³⁰). Extremely small cross sections (<10⁻¹⁸ cm²) have been found for asymmetric charge transfer between the rare gas atoms,^{28,29} but to our knowledge no measurements have been reported for charge transfer between Ne⁺ and C, N, and Cu. On the other hand the cross section for Penning ionization involving metastable neon atoms is typically large (~1 × 10⁻¹⁵ cm²^{31,32}). Thus, for the experimental conditions used to collect the data in Table I, Penning ionization appears to be the dominant ionization process for the minor species. Similar conclusions based on different experiments have been reported for an argon glow discharge.¹²

The analysis above is concerned with data obtained at low discharge currents (~5 mA). At higher currents smaller photon-induced voltage changes and smaller corresponding changes in the ion signals were observed. Table II shows results for the change in the Cu⁺ signal as a function of current when the laser wavelength was tuned to the neon transition at 594.48 nm (1s₅-2p₄). At 40 mA no change in the Cu⁺ signal was detected, although a positive voltage signal was still observed. Thus, the Cu⁺ signal is insensitive to photon irradiation which alters the neon metastable atom population. At high discharge currents, the increased electron flux in the hollow cathode cavity causes electron impact ionization (3') to become the probable dominant ionization process for the minor species. Penning ionization (1') plays a minor role at best under these conditions.

V. Conclusions

Laser-induced ionization changes in a hollow cathode discharge offer interesting insights into the possible ionization mechanisms. Our studies suggest that Penning ionization is the dominant mode of ionization for the minor species at low discharge currents, while the competitive role played by electron impact ionization becomes more important at high currents. Although several spectroscopic reports have suggested mechanisms for photon-induced bidirectional conductivity changes in rare-gas discharges,^{14,15} we found it easier to deplete the metastable atom population (and the analyte ion, M⁺) than to produce the analytically attractive converse situation leading to analyte enhancement. It is difficult to speculate on the de-

gree of sensitivity enhancement which one may achieve by photon-induced increases in metastable atom populations. Nevertheless, additional studies investigating discharge and laser characteristics necessary for maximum analyte enhancement are warranted.

Acknowledgment. This work was supported in part by NIH Grant GM-14569.

References and Notes

- (1) (a) National Bureau of Standards. (b) University of Virginia. (c) On leave from Departamento de Análisis Instrumental, Escuela de Química y Farmacia, Universidad de Concepción, Chile.
- (2) (a) D. S. Gough, P. Hannaford, and A. Walsh, *Spectrochim. Acta, Part B*, **28**, 197 (1973); (b) C. G. Bruhn and W. W. Harrison, *Anal. Chem.*, **50**, 16 (1978).
- (3) J. R. McNally, Jr., G. R. Harrison, and E. Rowe, *J. Opt. Soc. Am.*, **37**, 93 (1947).
- (4) W. Grimm, *Spectrochim. Acta, Part B*, **23**, 443 (1968).
- (5) W. W. Harrison and N. J. Prakash, *Anal. Chim. Acta*, **49**, 151 (1970).
- (6) J. W. Coburn, E. Taglauer, and E. Kay, *J. Appl. Phys.*, **45**, 1779 (1974).
- (7) W. W. Harrison and C. W. Magee, *Anal. Chem.*, **46**, 461 (1974).
- (8) E. H. Daughtrey, Jr., and W. W. Harrison, *Anal. Chem.*, **47**, 1024 (1975).
- (9) P. F. Knewstubb and A. W. Tickner, *J. Chem. Phys.*, **36**, 674 (1962).
- (10) P. F. Little and A. von Engel, *Proc. R. Soc. London, Ser. A*, **224**, 209 (1954).
- (11) F. M. Penning, *Naturwissenschaften*, **15**, 818 (1927).
- (12) J. W. Coburn and E. Kay, *Appl. Phys. Lett.*, **18**, 435 (1971).
- (13) R. B. Green, R. A. Keller, G. G. Luther, P. K. Schenck, and J. C. Travis, *Appl. Phys. Lett.*, **29**, 727 (1976).
- (14) K. C. Smyth and P. K. Schenck, *Chem. Phys. Lett.*, **55**, 466 (1978).
- (15) K. C. Smyth, R. A. Keller, and F. F. Crim, *Chem. Phys. Lett.*, **55**, 473 (1978).
- (16) C. G. Bruhn, B. L. Bentz, and W. W. Harrison, *Anal. Chem.*, **50**, 373 (1978).
- (17) B. L. Bentz, C. G. Bruhn, and W. W. Harrison, *Int. J. Mass Spectrom. Ion Phys.*, **28**, 409 (1978).
- (18) Certain commercial equipment is identified herein in order to adequately specify the experimental procedure. Such identification does not imply recommendation by the National Bureau of Standards, nor does it imply that this equipment is the best available for the purpose.
- (19) W. L. Wiese, M. W. Smith, and B. M. Glennon, *Natl. Stand. Ref. Data Ser., Natl. Bur. Stand., No. 4*, 128 (1966); C. E. Moore, *ibid.*, **No. 35**, 76 (1971).
- (20) F. A. Sharpton, R. M. St. John, C. C. Lin, and F. E. Fajen, *Phys. Rev. A*, **2**, 1305 (1970).
- (21) S. L. Carter and H. P. Kelly, *Phys. Rev. A*, **13**, 1388 (1976); *J. Phys. B*, **8**, L467 (1975).
- (22) K. T. Taylor and P. G. Burke, *J. Phys. B*, **9**, L353 (1976).
- (23) J. M. Esteva, G. Mehman-Balloffet, and J. Romand, *J. Quant. Spectrosc. Radiat. Transfer*, **12**, 1291 (1972).
- (24) F. J. Comes and A. Elzer, *Z. Naturforsch. A*, **23**, 133 (1968). The laser-induced changes in O⁺ concentration were similar to those for N⁺ in our experiments; for photoionization of atomic oxygen, see R. B. Cairns and J. A. R. Samson, *Phys. Rev. A*, **139**, 1403 (1965).
- (25) M. Le Dourneuf, V. K. Lan, and A. Hibbert, *J. Phys. B*, **9**, L359 (1976).
- (26) W. D. Barfield, G. D. Koontz, and W. F. Huebner, *J. Quant. Spectrosc. Radiat. Transfer*, **12**, 1409 (1972), and references cited therein.
- (27) J. B. Hasted, "Physics of Atomic Collisions", 2nd ed., American Elsevier, New York, N.Y., 1972, pp 621–627.
- (28) F. C. Fehsenfeld, A. L. Schmeltekopf, P. D. Goidan, H. I. Schiff, and E. E. Ferguson, *J. Chem. Phys.*, **44**, 4087 (1966).
- (29) R. Johnsen, J. Macdonald, and M. A. Biondi, *J. Chem. Phys.*, **68**, 2991 (1978).
- (30) C. E. Moore, *Natl. Stand. Ref. Data Ser., Natl. Bur. Stand., No. 34* (1970).
- (31) D. A. Micha, S. Y. Tang, and E. E. Muschlitz, Jr., *Chem. Phys. Lett.*, **8**, 587 (1971); S. Y. Tang, A. B. Marcus, and E. E. Muschlitz, Jr., *J. Chem. Phys.*, **56**, 566 (1972).
- (32) R. H. Neynaber and G. D. Magnuson, *Phys. Rev. A*, **11**, 865 (1975); **14**, 961 (1976).